



Volute Casing Pumps

Vogel Series LSN

ACCORDING TO ISO 2828 / ISO 5199

VOGELPUMPEN
Adenauerstraße 20, A2, 52146 Würselen, Germany
+49 2405 2894 990
info@vogelpumpen.eu
www.vogelpumpen.eu



Technical Data

Performance Range:

- Capacity up to 500m³/h (1980USgpm)
- Head up to 150m (492feet)
- Speed 2950/3550rpm

Pump Sizes:

- DN 25 up to DN 150 (1" up to 6") Discharge

Temperature:

- -40°C up to +180°C (-40°F up to +350°F)

Casing Pressure:

- up to 16 bar (235 psig)
Pump sizes 50-32-315, 65-40-315, 80-50-315, 100-65-315, 125-80-315 and 125-100-315 up to 25 bar (363 psig)

Volute casing pumps for higher capacities, pump sizes up to DN 600 (24") and capacities up to 4600m³/h (20250USgpm) refer to design LS

Liquids:

- Clean and slightly contaminated fluids (without bigger solids)
- Cold and hot water
- Condensate and desalinated water
- Oil, brine, caustic and acid
- Suspensions

Applications:

- Water supply and water treatment
- Cooling water supply
- Hot water circulation
- District heating
- General industry
- Food and beverage industry
- Filter systems, ultra filtration
- Coolant filtration
- Parts washing machines
- Galvanisation and painting systems

Materials:

- Ductile iron - 0.7043
- Stainless steel - 1.4408
- Duplex - 1.4517



Horizontal volute casing pumps - model LSN - are built according to
ISO 2858 / EN 22858
ISO 5199 / EN 25199
ISO 3069, ISO 3661



Performance 2950rpm, 50Hz / 3550rpm, 60Hz

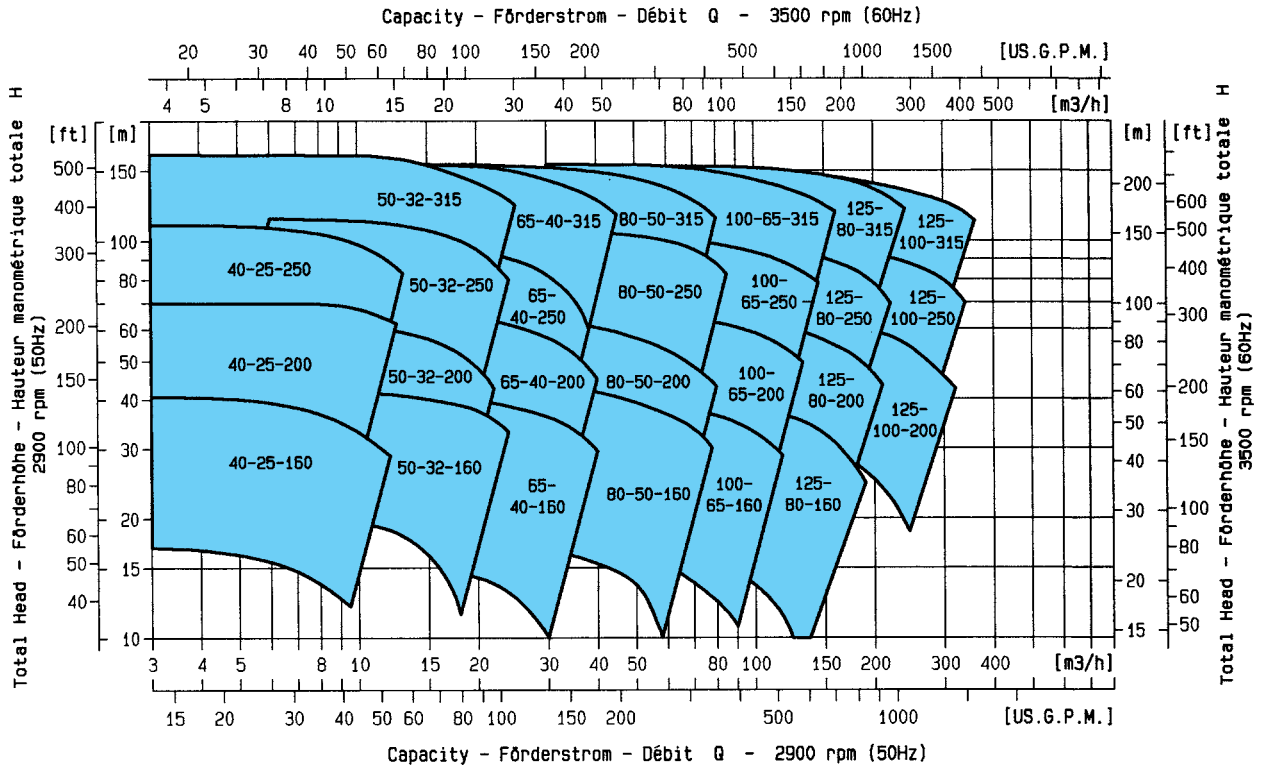

Performance 1450rpm, 50Hz / 1750rpm, 60Hz

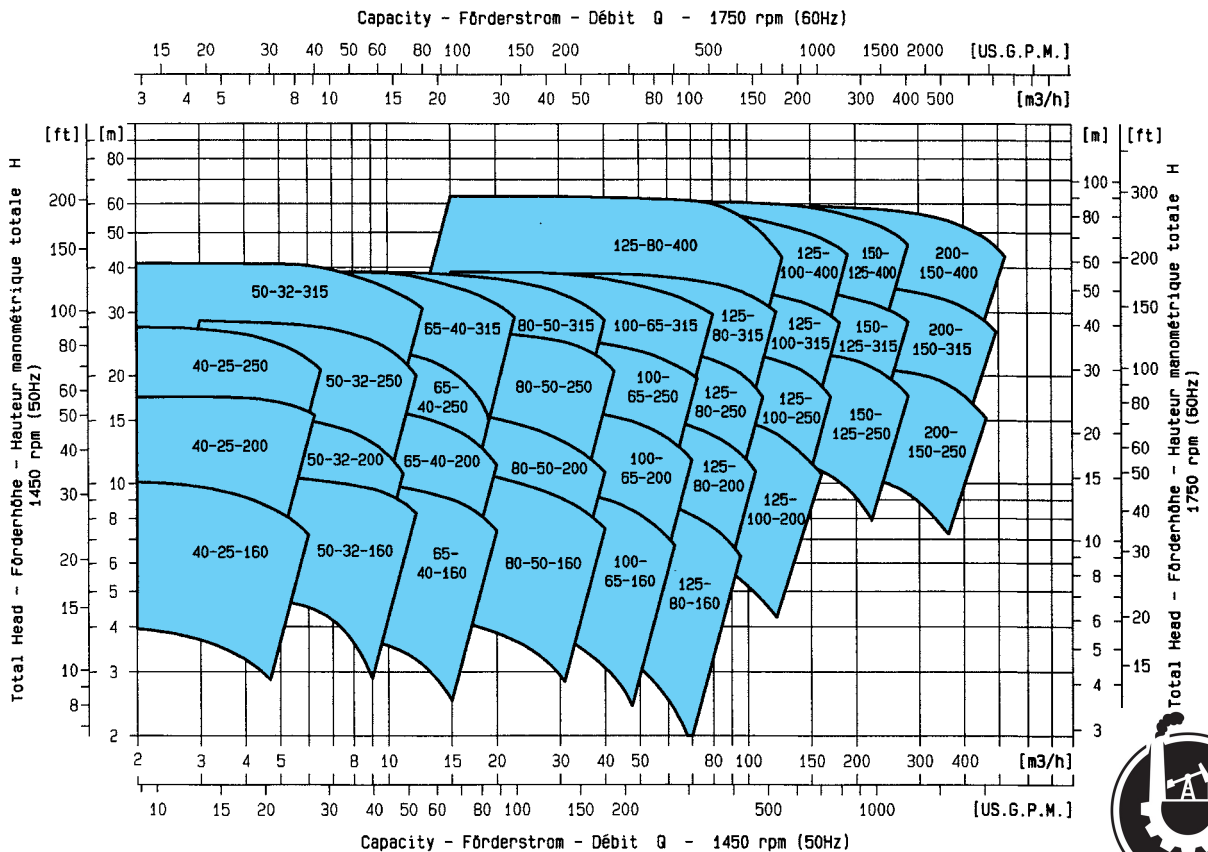

Cyclone Seal Chamber

- The patented design of the cyclone seal chamber improves the life time of the mechanical seal.
- Spiral grooves in the big conical seal chamber avoid contamination of the sealing environment with solids.
- Enlarged radial clearance and the big volume improve the cooling and lubrication of the mechanical seal.
- The selfventing design prevents the accumulation of gas (vapour) in the sealing environment.
- Seal chamber installation dimensions in accordance with ISO 3096 / DIN 24960.



Shaft Sealing

- The correct seal selection is essential for the life time of the mechanical seal. The flexible sealing system allows seal selection according customer requirements for individual seal designs and seal brands.
- Standard seal chamber with installing dimensions according to ISO 3096 (DIN 24960) combined with the features of the cyclone seal chamber design.
- Optional Vogel mechanical seals
 - Stationary seal design
 - Balanced design
 - No dynamic O-rings
 - Springs outside of the pumped liquid
 - Simplified installation due to integrated shaft sleeve

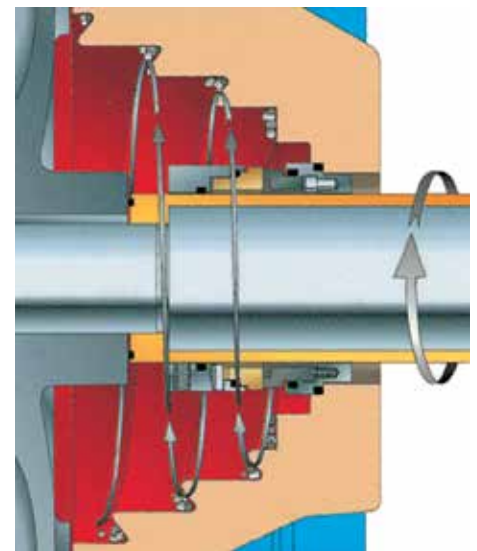

Bearing Frame

- The robust bearing frame design improves the lifetime of the pump.
- Oil sump with enlarged volume ensures cool and clean oil.
- Rigid shaft made of corrosion resistant stainless steel minimizes shaft deflection < 0,05mm.
- Double lip seals protecting the oil chamber.
- Options
 - Labyrinth seals
 - Oil sump cooling for temperatures > 160°C

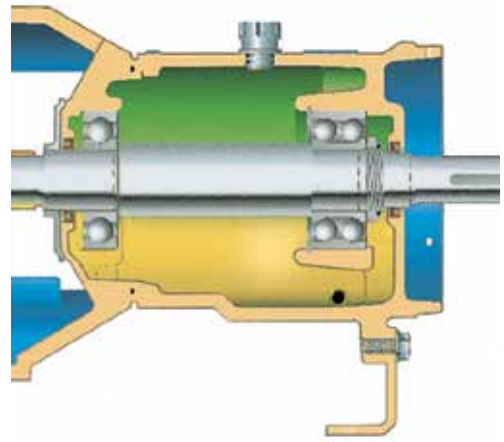

Inducers

- Reduction of pump NPSH value by 25 down to 50%.
- Ideal for applications at low system NPSH demands.
- Inducers are available for pump sizes DN 32 and bigger, standard material Duplex 1.4462
- Ability to handle liquids containing entrained gases.
- Enables lower positive suction heads and reduces required space on site - cost reduction.
- Application experience for 30 years.

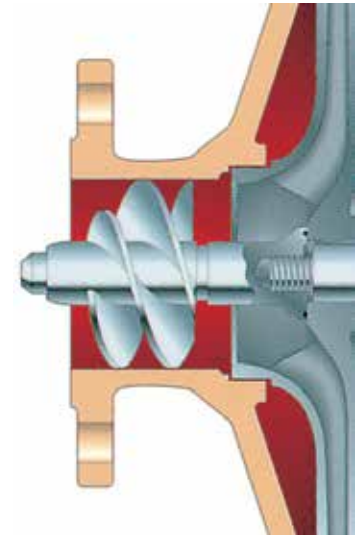
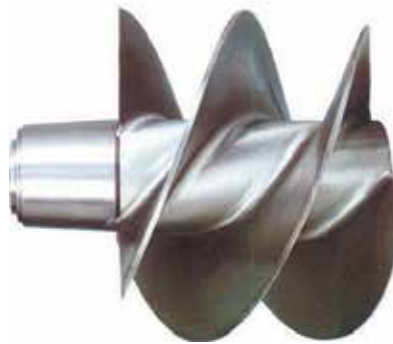

Heavy duty design for long term operation in industrial applications.

All design versions acc. to ISO 5199 / EN 25199

ISO 9001 + 14001 certifications guarantee high quality standards and reliability of our products as well as environmentally friendly production process.



Casing

- Heavy duty, top centerline discharge casing with integral cast feet provides maximum resistance to pipe loads for improved seal and bearing life.
- Minimum 3mm corrosion allowance maximizes pump life at corrosive and erosive applications.
- Back pull out design makes maintenance activities safe and simple.
- Standard 3/8" NPT casing drain for safe maintenance.
- Renewable wear ring maintains pump performance during full lifetime of pump (optional).
- Confined casing gasket provides safe pressure containment against gasket „blow out“ and protects alignment fits from corrosion for ease of maintenance.

Impeller

- Precision-cast enclosed impeller design provides maximum efficiency and optimum NPSH performance.
- Back vanes or balance holes reduce axial thrust and seal chamber pressure for extended bearing and seal life.
- Key driven for maximum reliability, eliminates spin-offs due to reverse rotation during start-up.

Engineered Shaft Sealing Environment

- Wide choice of sealing arrangements for maximum sealing flexibility.
- Patented „cyclone“ seal chamber improves lubrication, cooling and solid handling for ultimate seal life.

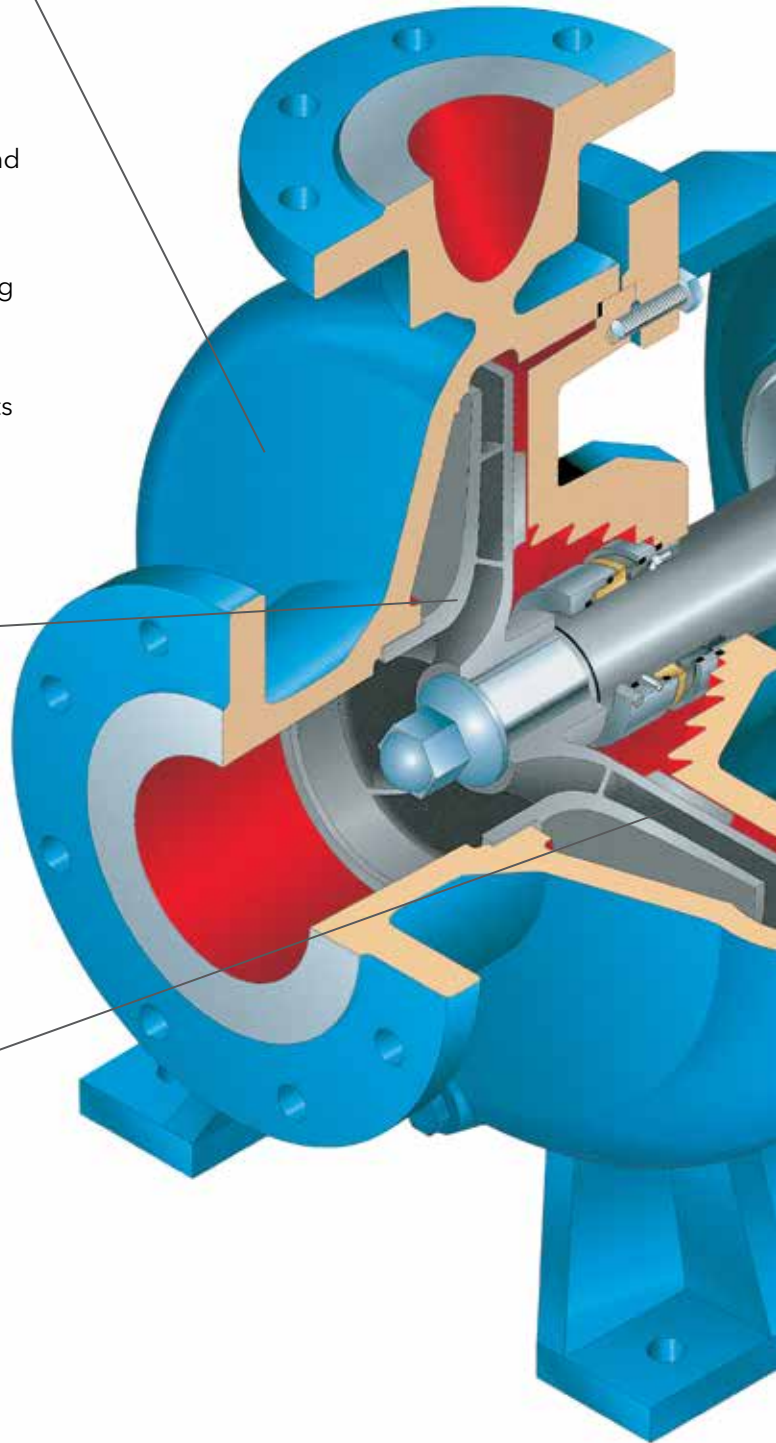

*Corresponding with to ISO 5199 and ISO 2858 for maximum reliability and easy installation.
Superior hydraulic design for maximum performance and extended mechanical reliability.*

VOGELPUMPEN
Adenauerstraße 20, A2, 52146 Würselen, Germany
+49 2405 2894 990
info@vogelpumpen.eu
www.vogelpumpen.eu



Standard design with improved reliability

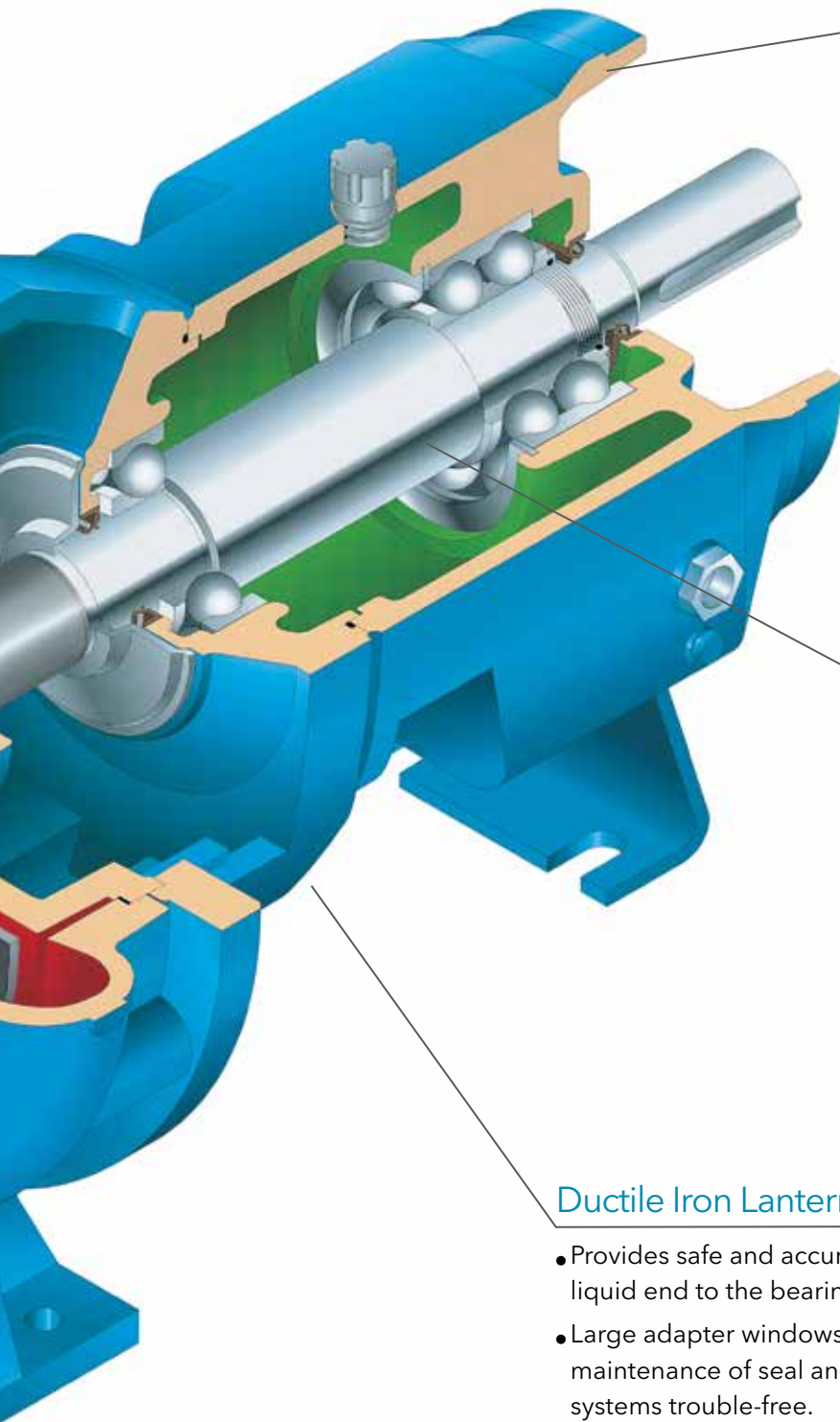

Bearing Frame

- Large capacity oil sump reduces oil temperature for extended bearing life.
- Heavy duty cast iron frame gives rigid support to shaft and bearings for longer service.
- Magnetic drain plug maintains a clean oil environment for extended bearing life.
- Standard double lip seals at pump and coupling end maintain a tight, clean operating environment.

Heavy Duty Shaft and Bearings

- Rigid shaft design for less than 0.05mm shaft deflection.
- Heavy duty ball bearings engineered to provide L10 bearing life in excess of 25,000 hours.
- Standard stainless steel shaft (1.4021) provides reliable power transmission and corrosion resistance at both the pump and coupling ends.

Ductile Iron Lantern / Frame Adapter

- Provides safe and accurate alignment of the liquid end to the bearing frame.
- Large adapter windows make installation and maintenance of seal and auxiliary support systems trouble-free.

Part and Material list

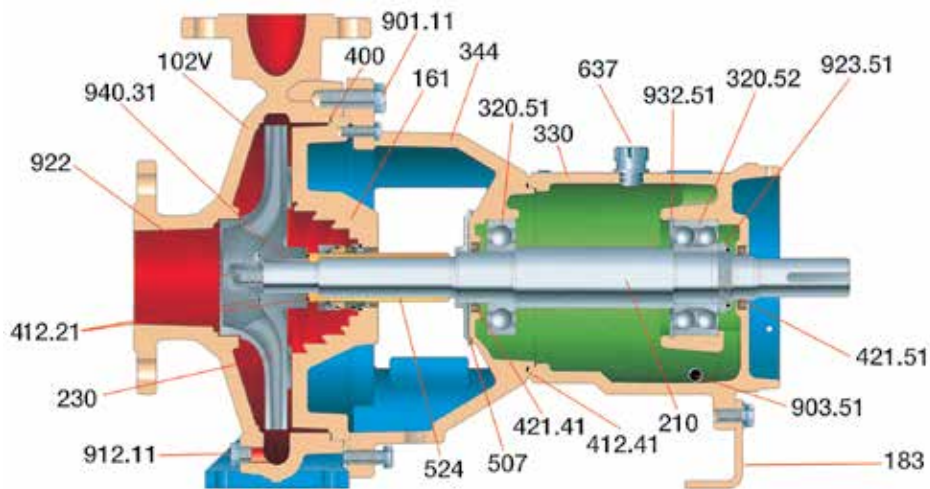

Item Number	Part Name	Ductile Iron (NL)	316SS (VV)	Duplex (WW)
102 V	Casing	Ductile Iron	316SS	Duplex SS
161	Seal Chamber / Stuffing Box Cover	Ductile Iron	316SS	Duplex SS
183	Support Foot	Carbon Steel		
210	Shaft	Stainless Steel (1.4021)		
230	Impeller	Cast Iron	316SS	Duplex SS
320.51	Radial Bearing	Single Row, Ball Bearing		
320.52	Thrust Bearing	Double Row Angular Contact Ball Bearing		
330	Bearing Bracket	Cast Iron		
344	Lantern	Ductile Iron		
400	Case Gasket	Non-Asbestos Aramid Fiber		
412.21	O-Ring for Shaft Sleeve & Impeller Nut	Teflon		
412.41	O-Ring for Bearing Bracket	Viton		
421.41	Oil Seal, Inboard	Lip Seal (Buna & Steel)		
421.51	Oil Seal, Outboard	Lip Seal (Buna & Steel)		
507	Flinger	Noryl 66		
524	Shaft Sleeve	Duplex SS (1.4462)		
637	Oil Filler Plug	Steel		
901.11	Casing Bolts, Hex Cap Screw	Stainless Steel (A2)		
903.51	Drain Plug	Steel Magnetic Tipped		
912.11	Case Drain Plug	316SS		
922	Impeller Nut	Duplex SS		
923.51	Bearing Lock Nut	Steel/Nylon		
932.51	Snap Ring / Circlip	Carbon Steel		
940.31	Impeller Key	Carbon Steel		

Other Parts Not Shown

236	Inducer (optional)	Duplex SS (1.4462)		
452	Packing Gland	316SS		
458	Lantern Ring	glass fibre PTFE		
461	Packing	PTFE Impregnated		
502.11	Wear Ring (optional)	1.4462		
642	Oil Level Sight Glass	Glass/Plastic		



LSN and HYDROVAR

Pumping System Solutions

By optimizing the pump performance according to system demand high potential of savings are achievable.

- Energy savings up to 70%.
- Increasing reliability and improved life time due to controlled operating conditions avoid dry run, head losses and cavitation.
- Reduced hydraulic forces improve bearing and mechanical seal life time.
- Lower installation costs due to elimination of control valves as well as panels and controllers.

Advantages

- Patented microprocessor based pump controller for variable speed operation, specifically developed for pump operation.
- Easy start up, without programming, simplifies installation.
- **Hydrovar Smart:** Hydrovar function and features without power limitation, combination with all standard frequency inverters possible.

Operating Options

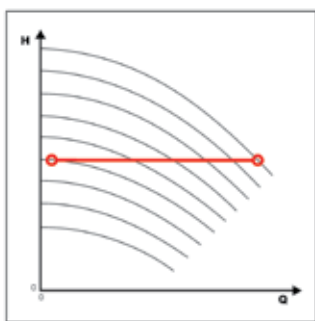

Constant Pressure

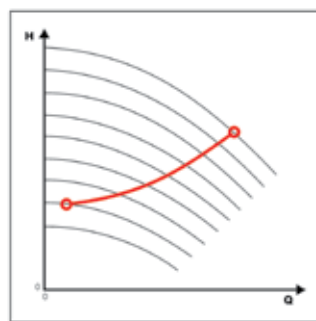

System Characteristics

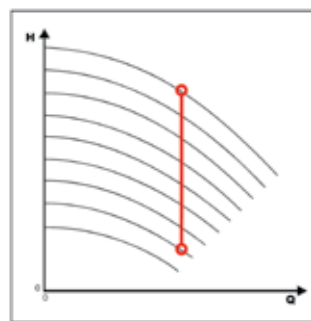

Constant Flow

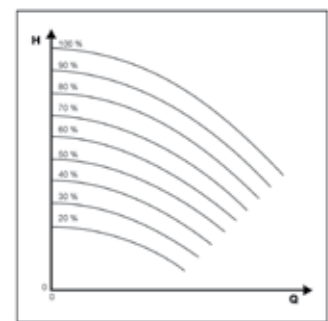

Actuator Mode



Controller Mode „Normal“

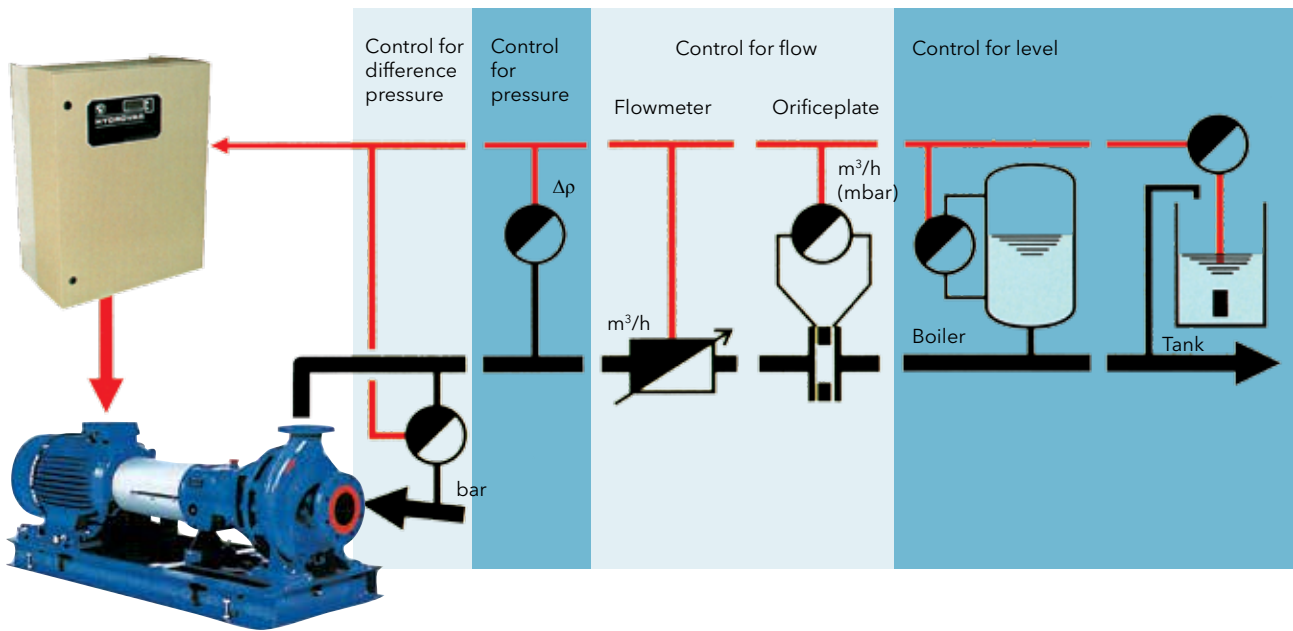

At controller mode „normal“ the operating frequency increases in case of decreasing signal measuring.

Controller Mode „Invers“

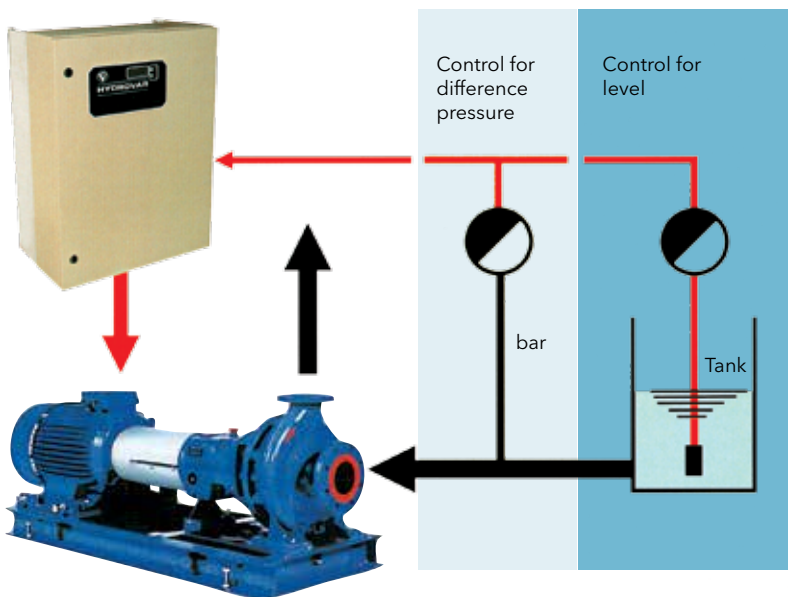

At controller mode „invers“ the operating frequency decreases in case of decreasing signal measuring.

For more detailed information of HYDROVAR refer to separate brochure.

Program Extension

Blockpumps - Design LSB

- Compact and low space block design
- Close coupled motors according to IEC, design B5
- Pump sizes DN 25 up to DN 150
- Motor power up to 37kW / 2950rpm and 30kW / 1450rpm
- Refer to separate brochure



Volute Casing Pumps - Design LS

- Extended performance range to model LSN, pump sizes up to DN 600 (24")
- Capacities up to 4600m³/h (20250USgpm)
- Refer to separate brochure

